

ZNB.X

Plate,
Equipment
Screws

Aluminium Body
Low Cooper

Emergency Button
Start/Stop Button
Signal Lamp
Electric Switch



ZONE 1-2 / 21-22

IP 65

$-20\text{ }^{\circ}\text{C} < T_a < +55\text{ }^{\circ}\text{C}$

Product

Certification

Marking

IP

Ambiant Temp.

Standarts

Cable Entries

Body

Gaskets

Paint

Rated Voltage

Frequency

Application

Aluminium Body Junction Boxes

SCA 20 ATEX 068X

II 2G Ex db IIB+ H2 T6 Gb

II 2D Ex tb IIIC T85°C Db

IP 65

-20 °C up to +55 °C

EN60079-0: 2018; EN60079-1: 2014; EN60079-31: 2014

See Hole Table

Low Cooper Aluminium Alloy

NBR o-ring on Body

Electrostatic Powder Coat

220-380V

50/60 Hz

Oil refineries, Chemical and petrochemical plants, Boiler rooms etc.

DIMENSIONAL DRAWING

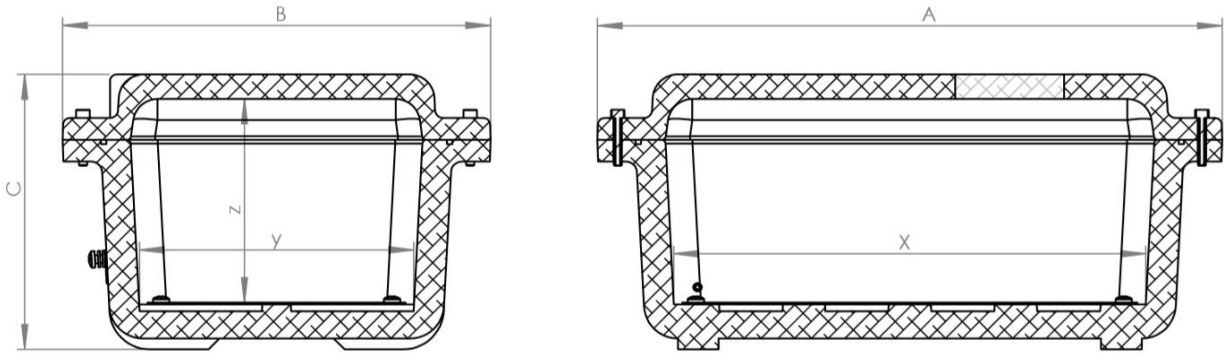

	External			Internal			Plate	weight
	A	B	C	x	y	z		
ZNB-1	210	145	121	140	77	76	130x67	
ZNB-2	275	200	143	200	123	104	190x113	
ZNB-3	330	230	166	240	140	125	230x130	
ZNB-4	460	315	202	345	200	151	335x190	
ZNB-5	520	350	226	410	235	169	400x225	
ZNB-6	660	430	285	535	310	226	525x300	
ZNB-7	786	536	310	655	405	270	645x395	

ZNB.

1, 2, 3, 4, 5, 6, 7

Empty for without Equipment
E for with Equipment



BODY DRILLING

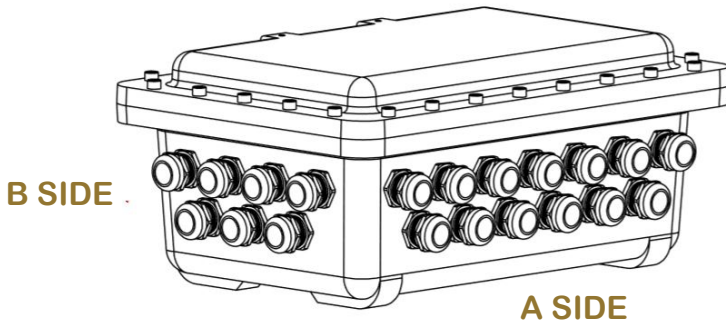

The threads for the cable glands, piping glands, reducers, unions, nipples and plugs to be used for the enclosure entries are given below.

	MAXIMUM NUMBER OF HOLE										
	Metric	A SIDE					B SIDE				
		M20	M25	M32	M40	M50	M20	M25	M32	M40	M50
NPT	1/2"	3/4"	1"	1 1/4"	1 1/2"	1/2"	3/4"	1"	1 1/4"	1 1/2"	
ZNB 1	3	3	2	-	-	2	2	1	-	-	
ZNB 2	7	7	3	2	2	5	3	2	1	1	
ZNB 3	9	9	5	2	2	5	5	2	1	1	
ZNB 4	13	13	11	5	4	7	7	5	2	2	
ZNB 5	15	15	13	9	5	9	9	7	5	3	
ZNB 6	29	29	23	14	12	17	17	11	6	6	
ZNB 7	32	32	23	14	14	23	23	14	8	8	

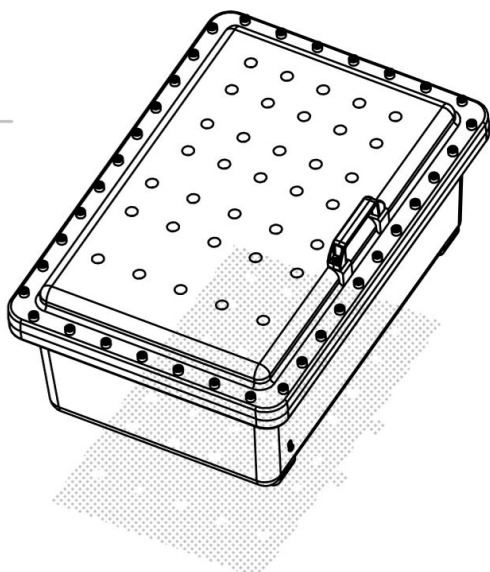

	Max. Number Of		Min Distance Of	
	Signal, Emergency, Start-Stop Buttons.	Switches	Signal, Emergency, Start-Stop Buttons.	Switches
ZNB 1	3	2	55	80
ZNB 2	6	2		
ZNB 3	9	3		
ZNB 4	15	8		
ZNB 5	18	12		
ZNB 6	26	18		
ZNB 7	35	18		

Too many combinations can be produced with equipment. However, the number of uses of any equipment will limit the number of uses of other equipment.